

Artikel-Nr.:0101158

Bez.: Cinch-Einbaubuchse, mit Schalter, Printausf. 90°, vergoldet, Gehäuse und Isolation Farbe rot

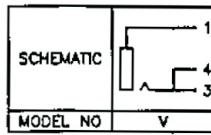
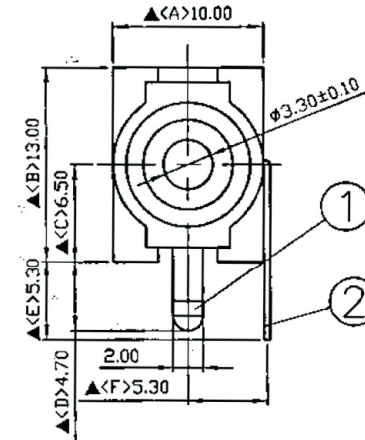
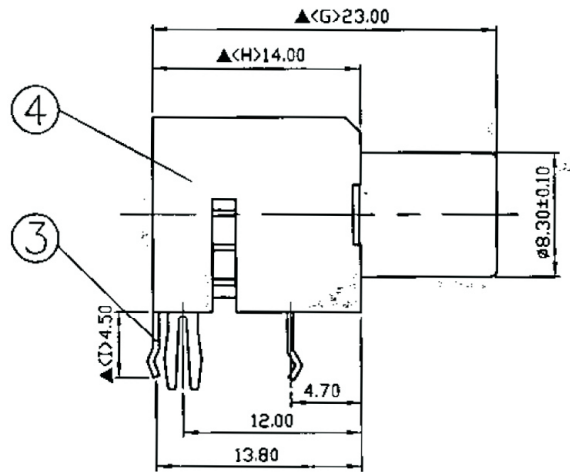

SPECIFICATIONS:

Contact Resistance : 30mΩ max
 Insulation Resistance : 100MΩ min. at DC 500V
 Dielectric Withstand Voltage : AC 500V for one minute
 Remark: ▲: The Most Important Dimension

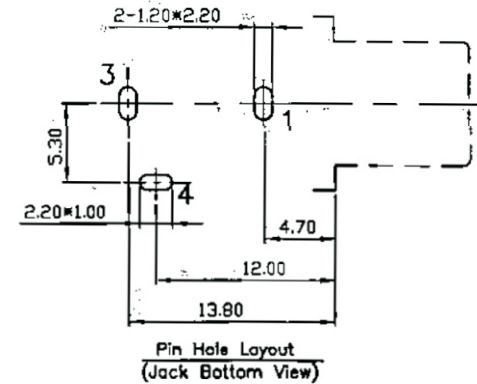
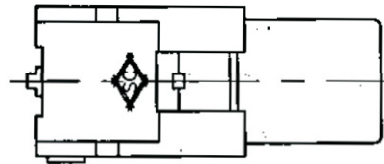

NO.	Description	Material	Q'TY	Finish
4.	Housing	PBT	1	Black Color
3.	Spring Terminal	0.3T Phosphor Bronze	1	Gold Plated
2.	Contact	0.4T Brass	1	Gold Plated
1.	Earth Terminal	0.5T Brass	1	Gold Plated

www.bkl-electronic.de

Technische Änderungen vorbehalten. Ausführungen können variieren. Sollten Sie ein Muster benötigen kontaktieren Sie uns bitte.

BKL-ELECTRONIC Kreimendahl GmbH • Märkenstück 14 • 58509 Lüdenscheid
 Tel: +49 (0)2351-3621-0 • Fax: +49 (0)2351-3621-29 • info@bkl-electronic.de

