

## Cable Assembly Instructions

Step 1

ALL PARTS OF THE CONNECTOR ARE SHOWN, A CRIMP TOOL IS NECESSARY TO COMPLETE THE TERMINATION

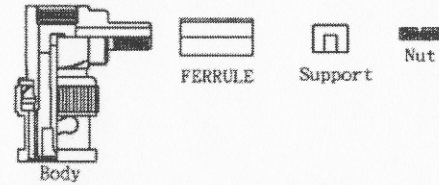

Step 2

STRIP THE CABLE INNER CONDUCTOR, DIELECTRIC, BRAID, AND JACKET

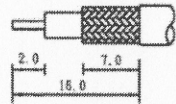

Step 3

INSERT MAIN BODY INTO BRAID AND DIELECTRIC.

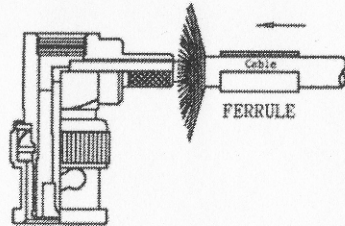

Step 4

SOLDER THE CONTACT PIN

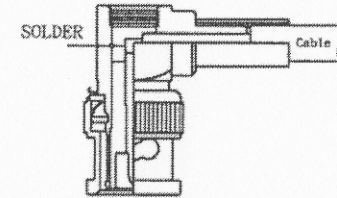

Complete

SLIDE THE FERRULE OVER BRAID AND CRIMP IT AND SLIDE THE SUPPORT AND SCREW ON THE NUT.

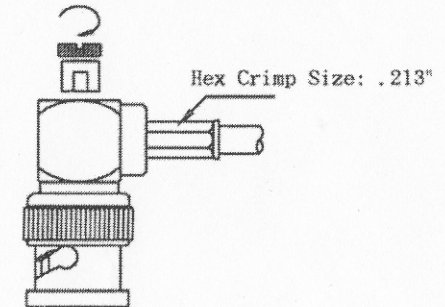

Take the actual assembly as the standard  
this drawing only provides reference

# www.bkl-electronic.de

Technische Änderungen vorbehalten. Ausführungen können variieren. Sollten Sie ein Muster benötigen kontaktieren Sie uns bitte.

BKL-ELECTRONIC Kreimendahl GmbH • Märkenstück 14 • 58509 Lüdenscheid  
Tel: +49 (0)2351-3621-0 • Fax: +49 (0)2351-3621-29 • info@bkl-electronic.de

